

Design and development of a long-term rumen simulation technique (Rusitec)

BY J. W. CZERKAWSKI AND GRACE BRECKENRIDGE

The Hannah Research Institute, Ayr KA6 5HL, Scotland

(Received 17 August 1976 – Accepted 21 February 1977)

1. The paper describes the development and construction of an apparatus for maintaining a normal microbial population of the rumen under strictly controlled conditions over long periods of time.

2. The apparatus is simple to construct and operate. It is possible to do four replicate experiments at the same time.

3. The results of three experiments are given. The experiments showed that when the steady-state was reached it could be maintained indefinitely, with the type and quantities of products of fermentation very similar to those in the rumen of donor animals, including the maintenance of normal protozoal populations for up to 49 d.

4. It was found that within wide ranges, the digestibility of rations and the output of products were independent of dilution rate.

5. Except for the lowest 'level of feeding', the digestibility was independent of the level of feeding. The output of products was proportional to the amount of food digested and was the same as would be expected in sheep on similar rations.

6. An experiment in which a ration of hay was changed to a mainly concentrate ration showed that the fermentation characteristics were determined mainly by the food given.

Many types of artificial rumen apparatus have been described (see review Czerkawski, 1976*a*). The apparatus constructed in this laboratory (Czerkawski & Breckenridge, 1969) was designed specifically for short-term work involving 6–8 h incubations and the possibility of measuring the gaseous exchanges was one of the main requirements. This apparatus and a small-scale version of it (Czerkawski & Breckenridge, 1970) have been used extensively in the studies of the mechanism of methane production and its inhibition. It was possible to 'trace out' several biochemical pathways and to develop new inhibitors of methane production.

Several experiments *in vivo* (Czerkawski, Christie, Breckenridge & Hunter, 1975; Czerkawski, 1976*b*) showed that the inhibition of methane production gives rise to gross changes in rumen metabolism. Some of these changes come about gradually over a period of weeks rather than days or hours and it is difficult to exert sufficient control or to interpret the results of experiments with animals. Therefore there was great need for a suitable long-term artificial rumen technique. A simple continuous culture procedure was discounted because it does not simulate the conditions in the rumen sufficiently (e.g., see Isaacson, Hinds, Bryant & Owens, 1975). Usually the protozoal concentrations decrease and often protozoa disappear altogether. Sometimes the bacterial metabolism bears little relation to that of the rumen of the donor animal and it is often necessary to stimulate the fermentation by infusing clarified rumen fluid. Another drawback in using a commercial fermentor is the provision of one or at most two reaction vessels; this limits severely the type of comparative work that can be undertaken.

In designing the apparatus described here the following requirements had to be met: (a) the reaction vessels should contain solid phase (partly digested food) as well as the liquid, the contents should be mixed so that there are no completely dead spaces, but the contents should not be too homogeneous. Thus, finely ground food and an efficient stirrer or gas purge were rejected at the outset. These deviate too much from the conditions obtaining in

the rumen; (b) the reaction vessels must be gas-tight and there must be a provision for quantitative collection and measurement of gases. Therefore, a method of continuous bubbling of gas through the reaction mixture such as used in many fermenters was discounted; (c) the apparatus must be reliable so that it can function without breakdown for 4–8 weeks, and must be of simple construction. Many of the gadgets that are usually found in a one-vessel fermenter (e.g. automatic pH control, provision of semi-permeable membranes or ion exchange for removal of products, e.g. see Slyter, Nelson & Wolin, 1964) could not be built into a four-vessel apparatus without making the running and servicing procedure unmanageable.

The apparatus described by Aafjes & Nijhof (1967) and Gray, Weller, Pilgrim & Jones (1962) was used as a basis for our apparatus, but the design features had to accommodate the requirements listed previously. Some simplifications were introduced in spite of the prevalent consensus of opinion and subsequent direct experimentation showed that this course of action was correct.

EXPERIMENTAL

Animals and diet

For the first two experiments two sheep fitted with rumen cannulas were kept on a diet of 250 g goat mix (Czerkawski, 1976c), 500 g hay and 100 g sugar-beet nuts (SBN) and fed at 09.00 and 16.00 hours. In the last experiment one sheep was given a diet of hay only (1000 g/d) and another sheep was given hay (200 g/d) and goat mix (800 g/d). Samples of rumen contents (approximately 1 l from each sheep) were taken before the morning feed as described previously (Czerkawski & Breckenridge, 1969). The samples were strained and pooled. Samples of solid rumen contents were taken using long tongs and also pooled.

Analytical procedures

Volatile fatty acids (VFA). The concentrations of VFA in the effluent were determined as described by Cottyn & Boucque (1968) using a column of 50 g Carbowax 20M TPA/kg Chromosorb G (Perkin-Elmer, Beaconsfield, Bucks.) in a gas-liquid chromatograph (Model 104; Pye-Unicam, Cambridge) at 130°.

Other determinations. Total bacterial and protozoal counts were made as described previously (Czerkawski *et al.* 1975). The diaminopimelic acid (DAP), aminoethylphosphonic acid (AEP), ammonia and total nitrogen were determined as described by Czerkawski (1974, 1976b). The ammonia-N was determined after distillation in Conway units by the ninhydrin method of Jacobs (1960). The particulate dry matter (DM) in the effluent was determined by centrifuging 20–50 ml preserved suspension at 15000 g for 30 min, washing the residue twice with water and drying at 105° to constant weight. For day to day monitoring of the course of fermentation 'protein' in the effluent was determined by the method of Toennies & Feng (1965). In this method the particulate matter is precipitated with trichloroacetic acid, the residue is extracted briefly with hot alkali and the protein in the extracts is determined by the Folin reagent, using bovine serum albumin as a reference standard. A better estimate of protein was obtained from analyses of α -amino groups. The dried particulate matter was hydrolysed overnight in 6 M-hydrochloric acid and the hydrolysate was passed through a small Celite-charcoal column. The diluted solution of amino acids was used for determination of the α -NH₂ group by the method of Spies (1952), using alanine as standard. Previous work showed a high extent of correlation between α -NH₂ group content and the sum of amino acid contents determined using an amino acid analyser (Czerkawski, 1976c).

Microscopic examinations of the effluents showed that they contained virtually no

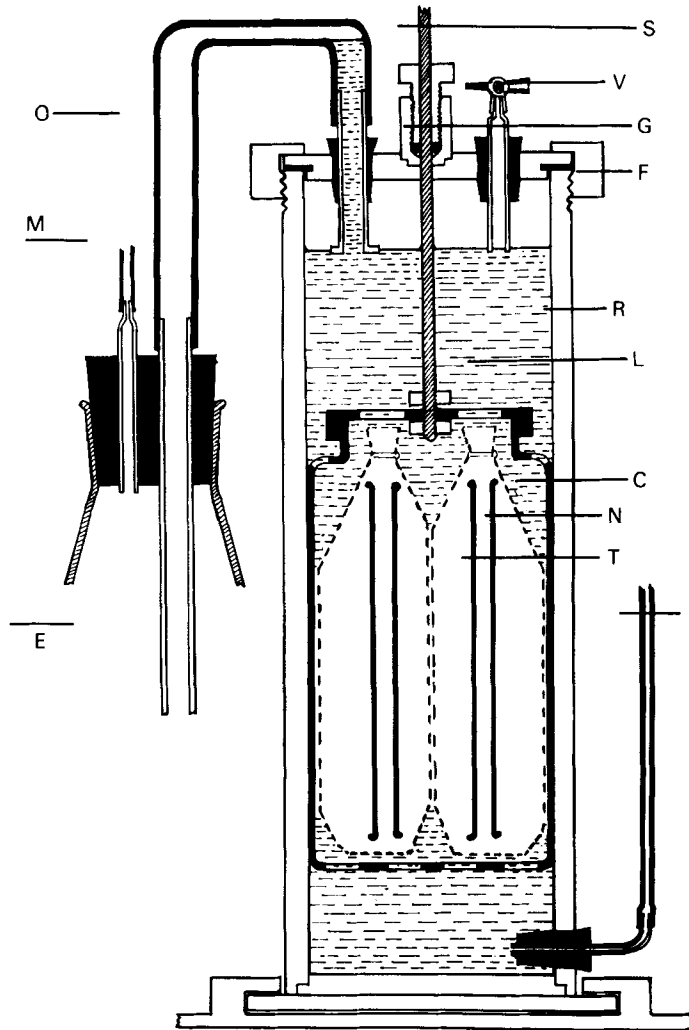

Fig. 1. Schematic diagram of one unit of the four-vessel long-term artificial rumen. (□), Made of perspex, (■), made of rubber or polyethylene. The driving shaft (S) was made of stainless steel. V, Sampling valve; G, gland (gas-tight); F, flange; R, main reaction vessel; L, rumen fluid; C, perforated food container; N, nylon gauze bag; T, rigid tube; I, inlet of artificial saliva; O, outlet through overflow; M, line to gas-collection bag; E, vessel for collection of effluent.

undigested food particles. The analyses of the contents of bacterial and protozoal markers in the effluent particulate matter and in the undigested food indicated that protozoa and bacteria could account for most of the DM in the former and that the latter might contain 100–130 g microbial matter/kg. Thus, the total microbial output was larger than the microbial output in the effluent and the digestibility of food (DM input minus DM in undigested food divided by the input) is under-estimated by approximately 0.04 units.

The volumes of gas produced were measured with a wet meter (M2475; Alex Wright & Co. (Westminster) Ltd, London) and gases were analysed chromatographically as described by Czerkawski & Clapperton (1968). Lipid extractions were made as described previously (Czerkawski *et al.* 1975).

Some results are reported as means of several values measured on consecutive days

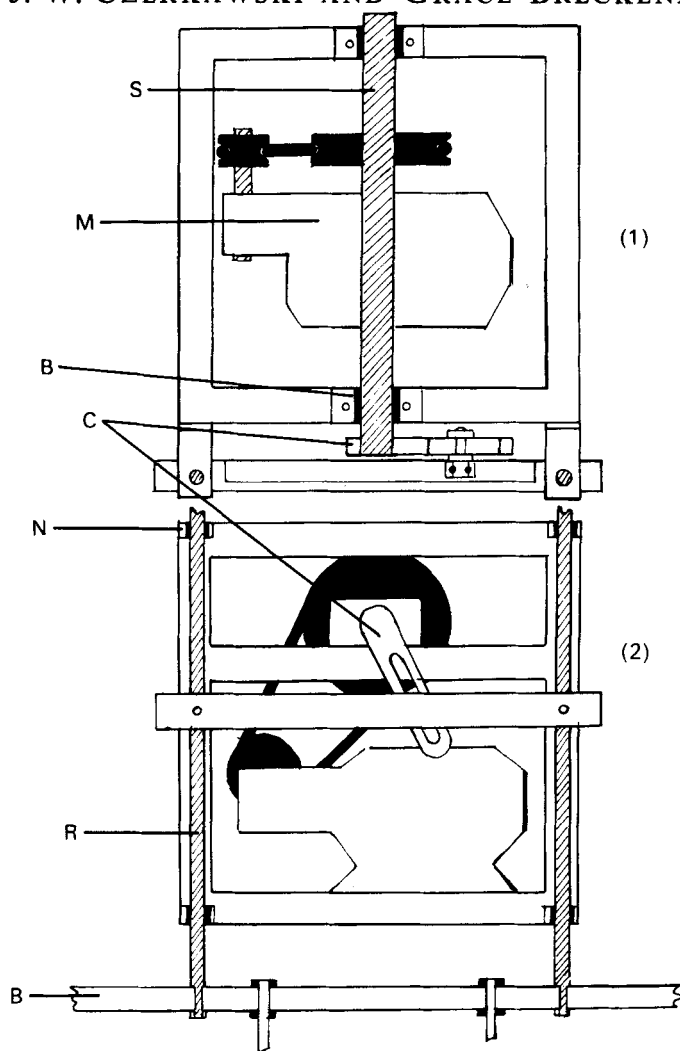

Fig. 2. Schematic diagram of the driving mechanism for the long-term rumen simulation apparatus. S, crank shaft; M, electric motor; B, bearings; C, crank (rotation→reciprocating movement); N, nylon guides; R, reciprocating rods; B, bar with attachments to stainless-steel shafts in reaction vessels.

together with the standard error of these means. In general the coefficient of variation was small and for economy of presentation, standard error was usually omitted. Some values are results of analyses of bulked samples and are usually given as means of duplicate analyses.

The apparatus and its operation

The complete unit consisted of four vessels. Each vessel had a capacity of 1 l (up to the overflow) and was secured to the base of a Perspex water tank with a 'bayonet' fitting (see Fig. 1). The temperature of the water bath was maintained at 39°.

Each reaction vessel consisted of a Perspex cylinder (254 × 76 mm) with an inlet at the bottom and sealed by means of a flat Perspex cover provided with a screw flange. The Perspex cover had two holes, one for a sampling tube provided with a three-way plastic tap (Pharmaseal, Liege, Belgium) and the other for the overflow tube. The overflow tube

was fitted through a rubber stopper into a 1 l conical collection flask. This rubber stopper also had an outlet connected to a 5 l gas bag (Jencons, Hemel Hempstead, Herts.) provided with a glass tap. A trap packed with glass wool was inserted in the gas line between the effluent collecting vessel and the gas bag to prevent droplets of moisture being carried over into the gas bag.

The food container inside the reaction vessel was made of a polyethylene reagent bottle with a screw cap of the same material, with an outer diameter which gave a sliding fit in the reaction vessel. The food was put into nylon bags (203 × 102 mm), made from fine mesh (1 perforation/mm) bags used for wine making (The Boots Co. Ltd, Nottingham) and the bags were closed by means of a plastic binder (Plasti-tie Synchemicals Ltd, London) and placed into the polyethylene container. The container was moved up and down by means of a stainless-steel rod passing through a gland and connected to the screw cap of the food container and to a crank actuated by a motor (see Fig. 2). The liquid could pass through the container via holes punched in the bottom, on the shoulder and in the screw cap. The motor speed was 20 rev./min and this produced a vertical stroke of 50–80 mm at 8 cycles/min.

General incubation procedure

On the first day of the experiment 500 ml strained rumen fluid, 200 ml artificial saliva (McDougall, 1948) and 100 ml water were placed in each reaction vessel. Solid rumen contents (80 g) were weighed into a nylon bag and one of these was placed inside the food container in each vessel together with a bag of food. The food used depended on conditions. The cap was screwed to the container and the assembly was lowered into the reaction vessel, and more water was added to make the total volume 1000 ml. Vaseline (Boots Pure Drugs Ltd, Nottingham) was applied to the rim of the vessel and the sealing ring and the vessel was closed. All this was done outside the water-bath to avoid spillage into the water-bath. The vessel was then placed in the water-bath, the 'bayonet' fitting was engaged and the effluent collection flask containing 10 ml mercuric chloride solution (one-fifth saturated solution) was connected to the overflow tube. The gas space above the reaction mixture was small (50–70 ml) and in the course of fermentation the gas would be displaced by the fermentation gases in 15–20 min. However, it was deemed wise to remove the air in the gas-space as soon as the vessel was closed and therefore the system was flushed through the three-way tap with carbon dioxide-N₂ (5:95, v/v) (common laboratory gas) for about 1 min without agitation and then for several minutes with the solids moving through the liquid. The three-way tap was closed and an empty gas bag was connected to the gas outlet tube.

The artificial saliva (McDougall, 1948) (pH adjusted to a suitable value) was infused by means of a four-channel peristaltic pump (LKB Ltd, South Croydon, Surrey) through an opening at the bottom of each vessel (see Fig. 1).

The next morning the infusion was stopped and the gas in the system (reaction vessel and collecting flask) was displaced by injecting slowly 1 l CO₂-N₂ (5:95, v/v) through the three-way tap. The bag was removed and the gas kept for analysis and measurement of volume. The agitating arrangement was stopped and the reaction vessels were removed from the water-bath. The vessels were opened and the bags of solid inoculum were removed and replaced by new bags of food. The original solid inoculum was rejected, but on subsequent days the bags that had spent 2 d in the vessels were removed and new bags of food were introduced. The bags that were removed from the vessels were placed inside polyethylene bags (160 × 80 mm) and 40 ml artificial saliva added. The contents were squeezed gently, the liquid was poured into a beaker and solid was washed with a further 40 ml artificial saliva. The combined washings were poured back into the reaction vessels. The closing and flushing procedure was carried out as before and the infusion started.

This procedure was repeated every morning, the bag which had been in the vessel for 2 d being removed and replaced by a bag of food. The bags were identified by using a system of attaching different-coloured polyethylene discs.

The residual material in the nylon bags was transferred to previously-weighed containers and the DM content was determined without any further washing.

Experimental procedures

Expt 1. In this experiment four vessels were used. The food used was the same in all vessels (7 g chopped hay, 7 g goat mix, 2 g SBN; 13.8 g DM) but the mean rate of outflow of liquid was different in each vessel, ranging from 350 to 970 ml/d. Thus, since the volume of the reaction vessel contents was 1 l, the dilution rates varied from 0.35 to 0.97/d. The same artificial saliva was used in all vessels (pH 9.5).

Expt 2. The object of this experiment was to study the effect of different levels of feeding. The smallest ration consisted of 3 g goat mix, 2 g hay and 1 g SBN. The other rations were two, three and four times these amounts. The DM input was 5.16, 10.33, 15.48 and 20.64 g/d respectively for the four rations. The mean outflow rate was similar in all vessels (approximately 750 ml/d) and no attempt was made to infuse a buffer of lower pH to the vessel with a low level of feeding.

Expt 3. Only two vessels were used in this experiment. For the first 15 d the ration in one vessel was 10 g chopped hay (8.67 g DM) and in the other vessel it was 2 g hay and 8 g goat mix (total DM 8.66 g). The inoculum was obtained from sheep given hay or mainly concentrate respectively. On day 16 the rations in the two vessels were interchanged and incubation was continued until day 34 when the experiment was terminated. The mean dilution rate in the experiment was approximately 0.7/d and the pH of the artificial saliva was 9.5.

RESULTS

Expt 1. Dilution rate

Fermentation characteristics. Some of the results obtained in an experiment that lasted 16 d are shown in Table 1. As can be seen in Table 1 the actual dilution rates differed slightly from the nominal value. The digestibility of DM was slightly greater at the highest dilution rate and there was virtually no difference in digestibilities when the two periods (days 5–10 and 11–16) were compared. Since the artificial saliva infused was of constant composition and pH, it is not surprising that the pH of the reaction mixture increased steadily with dilution rate. Only the pH values at lowest dilution rate could be considered to deviate considerably from the physiological values (6.5–7.5).

The concentrations of VFA in the effluent, and therefore the mean concentrations in the reaction mixtures varied inversely with the dilution rate. Values for the concentration ratio, propionic acid:butyric acid increased with the dilution rate, but in general these values were lower during the second period than during the first period. The value for propionic acid:acetic acid increased only slightly with dilution rate.

There was considerable variability in the concentrations of bacteria and protozoa in the effluent. On the whole, the concentrations of bacteria increased and concentrations of protozoa decreased with the duration of the experimental period, but the proportions of holotrich protozoa increased, except at the lowest dilution rate. The mean output of bacteria in the effluent (concentration \times dilution rate \times volume) increased with dilution rate, while the output of protozoa increased only slightly. The output of holotrich protozoa was considerably greater at high dilution rates than at the lowest dilution rate (approximately ten to twenty times greater).

End-products of fermentation. The output of CO₂ decreased with dilution rate (Table 2)

Table 1. *Expt 1.* Effect of dilution rates on the digestibility of dry matter (DM), the pH values of the reaction mixture, the concentration of volatile fatty acids (VFA) and micro-organisms in a long-term artificial rumen experiment*

(Mean values for period no. 1 (days 5–10) and period no. 2 (days 11–16))

Vessel no. ...	1		2		3		4	
	1	2	1	2	1	2	1	2
Period no. ...								
Dilution rate (/d)	0.33	0.34	0.58	0.60	0.82	0.80	0.94	0.96
DM digestibility	0.60	0.60	0.65	0.61	0.62	0.62	0.68	0.66
pH	6.26	6.22	6.95	6.96	7.16	7.15	7.22	7.27
VFA concentration (mmol/l)								
Acetic	92.2	95.6	66.3	63.3	46.2	51.1	41.4	43.5
Propionic	21.5	22.0	15.2	14.8	12.3	12.5	10.2	10.2
Butyric	27.7	30.0	12.9	14.0	9.4	10.8	7.3	8.2
Microbial concentrations (no./ml)								
Bacteria ($\times 10^9$)	9.8	16.3	7.6	10.2	10.1	8.1	7.7	9.9
Protozoa ($\times 10^6$)	1.26	0.45	0.64	0.35	0.35	0.34	0.40	0.36
Holotrichs (%)	1.6	0.2	16.2	30.9	12.9	16.7	7.6	16.0

* For details, see p. 376.

Table 2. *Expt 1.* Effect of dilution rate on fermentation in a long-term artificial rumen*

(Mean values for period no. 1 (days 5–10) and period no. 2 (days 11–16))

Vessel no. ...	1		2		3		4	
	1	2	1	2	1	2	1	2
Period no. ...								
Gas production (mmol/d)								
Methane	15.5	13.9	14.8	18.0	16.2	18.4	15.4	16.5
Carbon dioxide	50.3	47.0	49.0	48.1	40.0	46.2	37.9	38.6
VFA production (mmol/d)								
Acetic	29.9	32.3	38.2	38.4	37.9	40.6	37.2	40.8
Propionic	7.0	7.5	8.8	9.0	10.1	9.8	9.6	9.8
Butyric	9.2	10.2	7.5	8.4	7.7	8.6	6.8	7.8
C ₅ acids	2.8	3.8	2.4	3.0	3.1	3.2	1.7	1.6
Hydrogen balance† (mmol/d)								
Net 2H produced	78.2	85.0	80.6	93.6	91.2	98.4	88.0	97.2
Net 2H used	71.8	66.9	70.4	84.0	78.0	86.6	72.9	77.4
Balance	6.4	18.1	10.2	9.6	13.2	11.8	15.1	19.8
Microbial matter in the effluent (g/d)‡								
	Mean	SE	Mean	SE	Mean	SE	Mean	SE
Particulate dry matter	1.16	0.03	1.36	0.09	1.26	0.04	1.41	0.12
'Protein'§	0.47	0.02	0.53	0.02	0.46	0.02	0.54	0.03

* For details, see p. 376.

† For method of calculation, see p. 378.

‡ Mean for two periods, twelve values.

§ Determined by the method of Toennies & Feng (1965).

but this was clearly a function of increasing pH value of reaction mixtures. On the other hand the dilution rate had no marked effect on production of methane. Expressed on the basis of DM digested, the methane production was optimum at the intermediate dilution rates (approximately 43 l/kg digested food) and it was slightly lower at very low and high dilution rates (approximately 39 l/kg digested food).

Table 3. *Expt 2.* Effect of level of feeding on fermentation characteristics in a long-term artificial rumen*

(Mean values for days 10–17 of the experiment
(there was no difference between means for days 10–13 and days 14–17))

Food intake (g/d) ...	6	12	18	24
Dilution rate (/d)	0.78	0.78	0.76	0.75
pH	7.60	7.23	7.07	6.95
Amount of DM digested (g/d)	3.58	7.33	11.27	14.86
Digestibility (g/g)	0.66	0.71	0.73	0.72

DM, dry matter.

* For details, see p. 376.

The rate of production of acetate was lower at the lowest dilution rate used than at the other dilution rates, at which the VFA production was the same. At the lowest dilution rate the production of butyrate was higher than with other rates used. The output of microbial matter and protein was related to the dilution rate in the same way as the production of acetate and propionate and the mean amount of microbial matter produced and recovered in effluent at all dilution rates was 22.8 g/mol VFA. The 'protein' content of this microbial matter determined by the method of Toennies & Feng (1965) was also constant at 370 mg/g.

Assuming that the only substrate was glucose then its conversion to VFA and methane would result in net production (+) and utilization (–) of the following amounts (mol/mol product) of hydrogen: acetate +2, propionate –1, butyrate +2, C₅ acids –1, methane –4. The H balance is defined as an algebraic sum of these quantities and in all our experiments so far it was positive, showing that some H must have been used in reactions not considered here. Small amounts of H could have been used in such processes as production of succinic acid or hydrogen sulphide or hydrogenation of unsaturated fatty acids in the diet. Some of the extra H may have been used in the synthesis of microbial matter.

The mean concentration of VFA in the rumen of donor sheep was approximately 70 mmol/l. This concentration could be achieved in the apparatus described when the dilution rate is approximately 0.75/d. It is judged on the basis of present experiments that a dilution rate of less than 0.5/d is too low and does not simulate the conditions in the rumen. Although no attempt was made to use a dilution rate greater than 1.0, there would be little point since the concentration of products would be too low to determine them accurately and one would have to deal with very large volumes of artificial saliva and effluent.

Expt 2. Levels of feeding

The results of this experiment are summarized in Tables 3–5. It can be seen in Table 3 that the dilution rates were similar in all vessels and were within the range recommended on the basis of results of Expt 1. In general the mean pH value of the reaction mixtures decreased with the amount of food used. This was clearly due to decreased acid production with decreasing amounts of food. The digestibility of DM was slightly lower with the lowest level of feeding than with the other levels of feeding.

As expected (Table 4), the output of gases and acids increased with the level of feeding. The mean value for propionic acid:acetic acid was independent of the level of feeding (mean value 0.25) and butyric acid:acetic acid increased slightly (mean value 0.20). The microbial DM output in the effluent also increased with the amount of food given, but not in the same way as the end-products of fermentation. The output of various N compounds increased with the level of feeding.

Table 4. *Expt 2.* Output of gases, VFA, microbial matter and nitrogen during fermentation of various amounts of food in a long-term artificial rumen*

(Mean values with their standard errors for days 10-17 of the experiment)

Food intake (g/d) ...	6		12		18		24	
	Mean	SE	Mean	SE	Mean	SE	Mean	SE
Gas production (mmol/d)								
Methane	4.9	0.2	11.9	0.4	19.2	0.5	23.9	1.5
Carbon dioxide	8.0		26.7		51.8		74.3	
VFA production (mmol/d)								
Acetic	13.9	0.4	31.7	0.4	43.8	0.9	48.8	1.3
Propionic	3.6	0.1	7.8	0.15	10.9	0.15	12.1	0.3
Butyric	2.6	0.1	6.0	0.12	8.9	0.3	11.9	0.6
C ₅ acids	0.6	0.03	2.1	0.1	3.3	0.1	4.4	0.3
Total	20.6	0.4	47.6	0.5	66.9	1.0	77.2	1.5
Microbial dry matter in effluent (g/d)	0.27		0.94		1.44		1.68	
N compounds in effluent								
Total N (mg/d)	81.1		183.3		275.7		307.1	
NH ₃ -N (mg/d)	22.7		36.6		68.5		107.1	
'Protein' (g/d)†	0.11		0.40		0.60		0.65	
α -NH ₂ group (mmol/d)	1.0		2.8		3.9		4.2	
Diaminopimelic acid (μ mol/d)	6.9		16.2		20.1		25.3	

* For details, see p. 376.

† Determined by the method of Toennies & Feng (1965).

Table 5. *Expt 2.* Calculation of outputs on the basis of dry matter (DM) digested in a long-term artificial rumen with different amounts of food*

Food intake (g/d) ...	6	12	18	24
End-products (mol/kg DM)				
Methane	1.41	1.64	1.71	1.60
Carbon dioxide	2.29	3.64	4.60	5.00
VFA	5.92	6.49	5.94	5.20
Microbial matter in effluent (g/kg DM)				
DM	77.6	128.2	127.8	113.0
True protein (102 \times mol α -NH ₂)	29.4	39.0	35.3	28.18
Diaminopimelic acid (DAP)	0.38	0.42	0.34	0.32
Microbial measurements				
(DAP: α -NH ₂) \times 100	0.69	0.58	0.52	0.60
Protozoa (no./ml ($\times 10^4$))	0.5	1.1	1.2	1.0

* For details, see p. 376.

When the results were calculated on the basis of DM digested, it became apparent (Table 5) that the lowest and highest levels of feeding gave results that differed from those obtained with intermediate levels of feeding. The production of methane and VFA was higher at the intermediate levels and output of microbial DM and protein in the effluent was considerably higher at these levels. The ratio, DAP: α -NH₂ (an indirect measure of bacterial matter in microbial suspension) was lower and protozoal concentrations were higher at the two intermediate levels of feeding. Approximately 450 mg N/g effluent particulate matter was in the form of NH₃ or amino acids. Thus approximately half of the N in the effluent particles was in other compounds (e.g. nucleic acids, amino sugars).

Table 6. *Expt 3.* Output of methane and volatile fatty acids in effluent (mol/kg DM digested) during fermentation of roughage (hay) or concentrate (goat mix-hay (8:2, w/w)) in long-term artificial rumen.*

(In vessel no. 1 roughage was fed during period no. 1 (days 1-15) and concentrate during period no. 2 (days 16-35), while in vessel no. 2 concentrate and roughage were fed during period nos. 1 and 2 respectively. The results are mean values for four consecutive days; mean values for the two periods (days 4-15 and days 24-35) are also given)

Period on experiment (days) ... Vessel no.	Period no. 1						Period no. 2				
	4-7	8-11	12-15	4-15		24-27	28-31	32-35	24-35		
				Mean	SE				Mean	SE	
Digestibility	1	0.57	0.54	0.53	0.54	0.01	0.70	0.73	0.70	0.71	0.01
	2	0.72	0.75	0.72	0.73	0.01	0.54	0.54	0.56	0.55	0.01
Methane	1	1.67	1.75	1.69	1.68	0.07	1.35	1.39	1.52	1.42	0.08
	2	1.44	1.45	1.37	1.42	0.08	1.66	1.66	1.80	1.70	0.04
Acetic	1	5.13	5.41	4.88	5.03	0.14	3.18	3.20	3.60	3.33	0.11
	2	3.63	3.10	3.00	3.24	0.14	4.75	4.80	5.13	4.90	0.13
Propionic	1	1.16	1.10	1.13	1.13	0.04	1.09	1.05	1.19	1.11	0.03
	2	1.15	1.06	0.97	1.06	0.04	1.17	1.21	1.28	1.22	0.04
Butyric	1	0.51	0.60	0.57	0.56	0.02	1.03	0.97	0.97	0.99	0.03
	2	0.78	0.72	0.87	0.79	0.03	0.63	0.59	0.58	0.60	0.01
C ₆ acids	1	0.16	0.23	0.23	0.21	0.01	0.48	0.41	0.45	0.45	0.02
	2	0.30	0.35	0.40	0.35	0.02	0.26	0.28	0.29	0.28	0.02

* For details, see p. 376.

Table 7. *Expt 3. Distribution of microbial matter between effluent and undigested residues during fermentation of roughage and concentrate (goat mix-hay (8:2, w/w)) diets in the artificial rumen.*

(Mean values of analysis of four bulked samples)

Outputs	Roughage diet		Concentrate diet	
	Effluent particulate matter	Undigested residue	Effluent particulate matter	Undigested residue
DM (g/d)	0.27	3.96	0.82	2.44
Diaminopimelic acid (DAP) (mg/d)	0.74	1.16	1.68	0.50
Aminoethylphosphonic acid-P (AEP-P) (μ g/d)	18.9	52.2	42.5	29.7
Microbial DM* (g/d)	0.30	0.54	0.69	0.25
	0.84		0.94	

DM, dry matter.

* It is assumed that the DAP content of bacteria is 3.0 mg/g DM and that the AEP-P content of protozoa is 0.35 mg/g DM.

Expt 3. Change of diet

Some of the results of Expt 3 are summarized in Table 6; where the means for four consecutive days on each diet are given together with the over-all mean for 12 d. Clearly, the digestibility of hay was considerably lower than the digestibility of concentrate, whether the rations given during the first period or during the period after the 'change-over' of

rations. Moreover, there was no significant difference in digestibility of any one ration in the two vessels.

Similarly, the production of methane and acetate was greater with roughage than with concentrate and again there was no difference for any one ration in the two vessels. The production of propionic acid was nearly the same on both rations and the production of butyric acid was greater with concentrate than with roughage. The mean concentration of protozoa on the roughage ration was 4.2×10^3 /ml and on concentrate it was 3.8×10^4 /ml. On roughage rations there were approximately 30% holotrichs and no *Entodinium caudatum*, while on concentrate rations the protozoal population contained approximately 15% *Entodinium caudatum* and only 3% holotrichs.

The estimates of outputs of bacterial and protozoal matter in the effluent and in the undigested food are given in Table 7. With the concentrate diet about 30% of the total microbial matter was associated with the undigested food, while on the roughage diet the corresponding proportion was nearly 70%. With both diets the protozoa in the effluent appeared to account for 18% of the microbial matter and in the undigested residue the proportion was greater (approximately 30%).

DISCUSSION

Initial exploratory experiments with our technique (Rusitec) showed that the concentration of substances in the reaction vessels was not constant throughout the day. Usually the concentrations increased after feeding and then decreased. The concentrations of micro-organisms increased during 1–2 h after feeding and then decreased to a value that did not change much through the remainder of the day. The VFA concentrations showed a broad maximum 5–10 h after feeding, but the over-all increase was not very large (less than 20% of the prefeed value). Thus, knowing the volume of the contents and the rate of outflow it should be possible to calculate the rates of output at any given time with respect to feeding and to integrate those rates to give the daily output. It is much simpler for most purposes to determine the concentration of substances in the effluent and knowing its volume to calculate the mean daily output and this was the normal procedure.

Most experiments showed that provided the diet is balanced it is possible to achieve the steady-state in 4–6 d. However, in one experiment (Czerkawski & Breckenridge, unpublished results), when relatively small amounts of poor rations were used, the digestibility of DM decreased to approximately 0.25 after 6 d of incubation and then increased to 0.57 by day 11 and remained steady thereafter. There were corresponding changes in other measurements. Thus, it was safer to make a convenient measurement daily before deciding that a steady-state had been reached.

The diurnal variation is unavoidable as long as a normal ruminant food is used and as long as it is fed once/d. Continuous feeding of solid food would create enormous practical difficulties and one of the most attractive features of the apparatus (simplicity of construction and operation) would be lost. Thus, if we accept variation during the day, we can define the 'steady-state' in the apparatus when the daily output of products of fermentation does not change significantly from day to day on a specified number of days.

The results of Expt 1 showed that within wide limits, the output of substances is independent of dilution rate as long as the conditions inside the reaction vessel remain the same. Thus, with the lowest dilution rate used the VFA concentrations were very high and therefore the mean pH value was lower than in the other vessels and it is possible that it was this rather than the low dilution rate that was responsible for differences in fermentation pattern. Although the lowest dilution rate was less than one-third of the highest dilution rate and although the concentrations of substances in the effluent were more than twice as

high at the lowest dilution rate as at the highest dilution rate, their total daily output was not very different from those in the other three vessels (in general the values were 10–20 % lower). From a practical point of view in future experiments, any convenient dilution rate can be chosen and small fluctuations in rates of infusion will not be a problem.

Our results do not agree with the commonly accepted view that rumen fermentation can be influenced by the dilution rate. Harrison, Beever, Thomson & Osbourn (1975) infused up to 12 l water/d into the rumen of sheep without any effect on dilution rate, but both the fermentation characteristics and the dilution rate changed when artificial saliva was infused. Thomson, Beever, Mundell, Elderfield & Harrison (1975) added mixed mineral salts (those found in artificial saliva) to the rations of lambs and showed that the dilution rate increased. The proportions of acetic acid increased and the proportions of propionic acid decreased when dilution rate (and mineral salt concentration in the diet) increased. Latham & Sharpe (1975) showed that the mineral salts in the rations of lambs increased the proportion of cocci in rumen bacteria. Separate nutritional tests showed that such coccoid micro-organisms grew better with bicarbonate (a major constituent of artificial saliva).

Isaacson *et al.* (1975) used a continuous-fermentation apparatus to study the effect of dilution rate on fermentation *in vitro*. Glucose was the only source of energy and it was necessary to infuse clarified rumen fluid, otherwise an abnormal microbial population developed and no methane was produced. In the successful experiments the production of acetate and methane was considerably greater than that found in the rumen and there were no protozoa. The dilution rate had no effect on production of acetate and very little effect on ATP yield. The production of propionic acid increased with dilution rate (cf. Thomson *et al.* 1975). The cell DM concentrations increased with dilution rate, but these concentrations were means for experiments done at different concentrations of glucose in the medium (i.e. means of values ranging from 0.36 to 1.55 mg/ml). Therefore the standard errors of single determinations associated with these values were large (approximately 60 % of the mean) and the authors stated: 'the possibility of significant interaction exists between glucose and dilution rate'.

The second experiment simulated the classical 'level of feeding' experiments with animals, with the proviso that the level of feeding was increased fourfold. In general the output of products increased with the amount of food in the vessel but not in proportion to the amount of food supplied. When the results were expressed on a 'per unit weight of food digested' basis the outputs were similar but in most instances the output was maximum between 12 and 18 g/d. Within these limits the output of products was proportional to the amount of food digested. With low levels of feeding the efficiency of food conversion decreased (cf. microbial DM in the effluent/unit food digested, Table 5) possibly due to extensive lysis of micro-organisms and re-synthesis, while with high levels of feeding the output could be decreased by physical factors, such as accessibility of food, sequestration and therefore loss in undigested residue etc. When the level of feeding was optimum, the growth and output of protozoa was higher and the output of NH_3 was lower than with low or high levels of feeding.

In no experiments done so far, did any two vessels with identical treatment develop different fermentation characteristics. Furthermore, when the same rations were used and the inoculum were from the same donor animal but taken at a different time, the fermentation characteristics were again similar. If in two vessels receiving the same treatment and giving virtually the same output of products the fermentation pattern in one vessel was changed for 9–25 d (e.g. inhibition of methane production), and then the treatment was discontinued, the fermentation characteristics returned to the pretreatment values and were essentially the same as in the untreated control vessel. The results of Expt 3 show clearly

that the fermentation measurements in two vessels were the same as long as the diet was the same, even though the original inoculum in each vessel was quite different. The transition period between the change of diets and achievement of steady-state (days 16–23) was monitored daily although the results are not reported here. Some outputs changed faster than others and some temporarily increased to values that were higher than the steady values with either diet.

It is difficult to judge how closely the *in vitro* technique simulates the *in vivo* system and what are the most appropriate measurements. The molar ratios acetic acid:propionic acid:butyric acid on roughage and concentrate diets in Expt 3 were 71:17:8 and 59:19:15 respectively. These ratios are well within the ranges of values found in the rumen of sheep given similar diets. Clearly, when the outputs are expressed as amounts of products/d, no comparisons can be made with the *in vivo* system, but such results can be very helpful when comparisons are made within a given experiment. For instance, the value for VFA production:methane production in Expt 3 was 4.1 and was not markedly different from the values found *in vivo* (4.5–5.3). However, there is no reason why comparisons between the real and simulated systems could not be made when the results are expressed on a 'per unit DM digested' basis. On this basis the productions of methane and VFA in most of our experiments with Rusitec were similar to those obtained with the same diets *in vivo*.

The comparisons of microbial outputs are more difficult since the measurements *in vivo* and *in vitro* are very uncertain, but even here, the estimated output of microbial matter *in vitro* was within the range of values estimated *in vivo*. For instance, it can be calculated from Tables 6 and 7 that for the roughage and concentrate rations the output of microbial matter would be respectively 178 and 150 g/kg DM digested and that the outputs expressed relative to VFA production would be 25.1 and 25.7 g/mol VFA produced.

Apart from the measurements already described, one can judge how close is the simulation of the real system in more qualitative, but important manner, namely maintenance of protozoal population, colour and smell of reaction mixture that could not be distinguished from the rumen contents of animals on the same diet.

The dilution rates in the rumen are usually in excess of 1.0/d and often approximately 1.5/d. When dilution rates of 1.0–1.5/d are used in continuous culture the protozoal numbers decrease markedly because the generation time of protozoa is greater than their residence time in the fermenter at these dilution rates. Abe & Kumeno (1973) suggested that the removal of protozoa from the rumen is slower than the outflow of fluid and they showed that protozoal numbers could be maintained provided the dilution rates were low. Dilution rate of 0.5/d could be used provided that the concentration of products was not too high and the pH was not too low. They achieved this by using an elaborate dialysis arrangement.

Recently, a procedure was described in which the solid and liquid could be removed at different rates during fermentation *in vitro* (Hoover, Crooker & Sniffen, 1976). An automatic intermittent feeding device was used, a proportion of reaction mixture was allowed to overflow and a proportion was removed through a filter. The reaction mixture was stirred mechanically and with N₂ gas. It was possible to maintain protozoal numbers and obtain reasonable digestibility of DM but difficulties were encountered in maintaining flows. The filters had to be changed at 48 h intervals and eventually at 24 h intervals (Hoover, Knowlton, Stern & Sniffen, 1976).

In our simple technique the concentration of products and the pH did not deviate very much from those found in the rumen of donor animals. Even though we used relatively low dilution rates there was no problem with removal of products. The removal of solid from the rumen is slow, with a large proportion of particles remaining in the rumen for 2 d or longer. In Rusitec, the food remains in the vessel for 2 d although over 70 % of the

digestible DM is removed during the first day. Perhaps it is this that enables the apparatus to simulate the rumen so closely.

The authors are grateful to Mrs C. Faulds for much of the expert analytical work and to Mr J. Henderson for construction of apparatus.

REFERENCES

- Aafjes, J. H. & Nijhof, J. K. (1967). *Br. vet. J.* **123**, 436.
Abe, M. & Kumeno, F. (1973). *J. Anim. Sci.* **36**, 941.
Cottyn, B. G. & Boucque, C. F. (1968). *J. agric. Fd Chem.* **16**, 105.
Czerkawski, J. W. (1974). *J. Sci. Fd Agric.* **25**, 45.
Czerkawski, J. W. (1976*a*). *Lab. Prac.* **25**, 15.
Czerkawski, J. W. (1976*b*). *Proceedings of the 7th Symposium on Energy Metabolism, Vichy, France*, p. 355. Clermont-Ferrand: G. D. Bussac.
Czerkawski, J. W. (1976*c*). *J. Sci. Fd Agric.* **27**, 323.
Czerkawski, J. W. & Breckenridge, G. (1969). *Br. J. Nutr.* **23**, 51.
Czerkawski, J. W. & Breckenridge, G. (1970). *Lab. Prac.* **19**, 717.
Czerkawski, J. W., Christie, W. W., Breckenridge, G. & Hunter, M. L. (1975). *Br. J. Nutr.* **34**, 25.
Czerkawski, J. W. & Clapperton, J. L. (1968). *Lab. Prac.* **17**, 994.
Gray, F. V., Weller, A. F., Pilgrim, A. F. & Jones, G. E. (1962). *Aust. J. agric. Res.* **13**, 343.
Harrison, D. G., Beever, D. E., Thomson, D. J. & Osbourn, D. F. (1975). *J. agric. Sci., Camb.* **85**, 93.
Hoover, W. H., Crooker, B. A. & Sniffen, C. J. (1976). *J. Anim. Sci.* **43**, 525.
Hoover, W. H., Knowlton, P. H., Stern, M. D. & Sniffen, C. J. (1976). *J. Anim. Sci.* **43**, 535.
Isaacson, H. R., Hinds, F. C., Bryant, M. P. & Owens, F. N. (1975). *J. Dairy Sci.* **58**, 1645.
Jacobs, S. (1960). *Analyst, Lond.* **85**, 257.
Latham, M. J. & Sharpe, M. E. (1975). *Proc. Nutr. Soc.* **34**, 113A.
McDougall, E. I. (1948). *Biochem. J.* **43**, 99.
Slyter, L. L., Nelson, W. O. & Wolin, M. J. (1964). *Appl. Microbiol.* **12**, 374.
Spies, J. R. (1952). *J. biol. Chem.* **195**, 65.
Thomson, D. J., Beever, D. E., Mundell, D. C., Elderfield, M. L. & Harrison, D. G. (1975). *Proc. Nutr. Soc.* **34**, 111A.
Toennies, G. & Feng, F. (1965). *Analyt. Biochem.* **11**, 411.